

**Závitové kruhové
čelisti šestihřanné
Hexagon die nuts
Sechskant -
Schneidmuttern
Плашки шестиугольные**

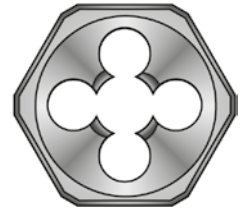

M
Metrický závit ISO DIN 13
Standard metric thread ISO DIN 13
Metrische Regelgewinde ISO DIN 13
Метрическая резьба ISO DIN 13

Licování: 6g / Tolerance: 6g /
Toleranz: 6g / Подгонка: 6g

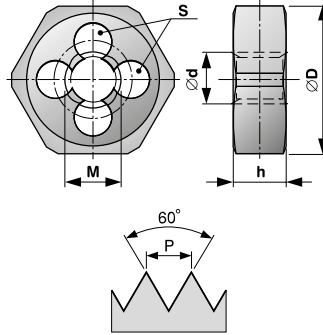

1,5P

	P	ØD	h	S		code
M 3	0,5	18	5	4	2,92	220 030
M 4	0,7	18	5	4	3,91	220 040
M 5	0,8	18	7	4	4,90	220 050
M 6	1	18	7	4	5,88	220 060
M 7	1	21	9	4	6,88	220 070
M 8	1,25	21	9	5	7,87	220 080
M 9	1,25	21	9	5	8,87	220 090
M 10	1,5	27	11	5	9,85	220 100
M 11	1,5	27	11	5	10,85	220 110
M 12	1,75	36	14	5	11,83	220 120
M 14	2	36	14	5	13,82	220 140
M 16	2	41	18	5	15,82	220 160
M 18	2,5	41	18	5	17,79	220 180
M 20	2,5	41	18	5	19,79	220 200
M 22	2,5	50	22	6	21,79	220 220
M 24	3	50	22	6	23,76	220 240
M 27	3	60	25	6	26,76	220 270
M 30	3,5	60	25	7	29,73	220 300
M 33	3,5	60	25	8	32,73	220 330
M 36	4	60	25	9	35,70	220 360
M 39	4	70	30	8	38,70	220 390
M 42	4,5	70	30	9	41,69	220 420
M 45	4,5	85	36	8	44,69	220 450
M 48	5	85	36	8	47,66	220 480
M 52	5	85	36	8	51,66	220 520
M 56	5,5	100	36	8	55,65	220 560
M 60	5,5	100	36	8	59,65	220 600
M 64	6	115	36	8	63,62	220 640
M 68	6	115	36	8	67,62	220 680



**BUČOVICE
TOOLS a.s.**

Materiál: HSS
Provedení: závit lapovaný
do M 26
Závit: pravý

Material: HSS
Execution: lapped thread
to M 26
Thread: right-hand

Werkstoff: HSS
Ausführung: geläpftes
Gewinde bis M 26
Gewinde: rechts

Материал: NO-инструментальная сталь; HSS
Изготовлено: резьба шлифованная до M 26
Резьба: правая

**Závitové kruhové
čelisti šestihorné
Hexagon die nuts
Sechskant -
Schneidmuttern
Плашки шестиугольные**

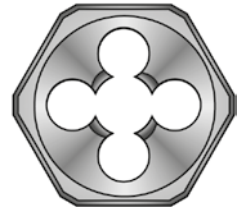
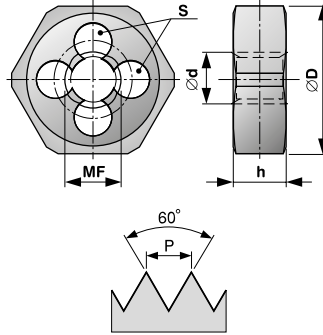

Licování: 6g / Tolerance: 6g /
Toleranz: 6g / Подгонка: 6g



1,5P

Jemný metrický závit ISO DIN 13
Fine metric thread ISO DIN 13
Metrische Feingewinde ISO DIN 13
Мелкая метрическая резьба ISO DIN 13

MF

	P	ØD	h	S		code
MF 3	0,35	18	5	4	2,94	220 031
MF 4	0,5	18	5	4	3,93	220 041
MF 5	0,5	18	5	4	4,93	220 051
MF 5	0,75	18	5	4	4,91	220 052
MF 6	0,75	18	7	4	5,91	220 061
MF 7	0,75	21	9	4	6,90	220 071
MF 8	1	21	9	5	7,88	220 081
MF 8	0,75	21	9	5	7,90	220 082
MF 9	1	21	9	5	8,88	220 091
MF 9	0,75	21	9	5	8,90	220 092
MF 10	1,25	27	11	5	9,86	220 101
MF 10	1	27	11	5	9,88	220 102
MF 10	0,75	27	11	5	9,90	220 103
MF 11	1	27	11	5	10,88	220 111
MF 12	1,5	36	10	5	11,85	220 121
MF 12	1,25	36	10	5	11,86	220 122
MF 12	1	36	10	5	11,88	220 123
MF 14	1,5	36	10	5	13,85	220 141
MF 14	1,25	36	10	5	13,86	220 142
MF 14	1	36	10	5	13,88	220 143
MF 15	1,5	41	14	5	14,85	220 151
MF 15	1	41	14	5	14,88	220 152
MF 16	1,5	41	14	5	15,85	220 161
MF 16	1	41	14	5	15,88	220 162
MF 18	2	41	14	5	17,82	220 181
MF 18	1,5	41	14	5	17,85	220 182
MF 18	1	41	14	5	17,88	220 183
MF 20	2	41	18	5	19,82	220 201
MF 20	1,5	41	14	5	19,85	220 202
MF 20	1	41	14	5	19,88	220 203
MF 22	2	50	16	5	21,82	220 221
MF 22	1,5	50	16	5	21,85	220 222
MF 22	1	50	16	5	21,88	220 223
MF 23	1,5	50	16	5	22,85	220 231
MF 24	2	50	16	6	23,82	220 241
MF 24	1,5	50	16	6	23,85	220 242
MF 24	1	50	16	6	23,88	220 243
MF 25	1,5	50	16	6	24,85	220 251
MF 25	1	50	16	6	24,88	220 252
MF 26	1,5	50	16	6	25,85	220 261
MF 27	2	60	18	6	26,82	220 271
MF 27	1,5	60	18	6	26,85	220 272
MF 28	2	60	18	6	27,82	220 281
MF 28	1,5	60	18	6	27,85	220 282
MF 28	1	60	18	6	27,88	220 283
MF 29	1,5	60	18	6	28,85	220 292
MF 30	2	60	18	6	29,82	220 301
MF 30	1,5	60	18	6	29,85	220 302
MF 30	1	60	18	6	29,88	220 303
MF 32	1,5	60	18	7	31,85	220 321
MF 33	3	60	25	8	32,73	220 330
MF 33	2	60	18	8	32,82	220 331
MF 33	1,5	60	18	8	32,85	220 332
MF 35	1,5	60	18	8	34,85	220 351
MF 36	3	60	18	9	35,76	220 361
MF 36	2	60	18	9	35,82	220 362
MF 36	1,5	60	18	9	35,85	220 363
MF 39	3	70	30	8	38,76	220 391
MF 39	2	70	20	8	38,82	220 392
MF 39	1,5	70	20	8	38,85	220 393

Materiál: HSS
Provedení: závit lapovaný
do M 26
Závit: pravý

Material: HSS
Execution: lapped thread
to M 26
Thread: right-hand

Werkstoff: HSS
Ausführung: geläpptes
Gewinde bis M 26
Gewinde: rechts

Материал: NO-инструмен-
тальная сталь: HSS
Изготовлено: резьба
шлифованная до M 26
Резьба: правая

